

MECHANICAL MOVEMENT DIMENSIONAL SPECIFICATIONS

KIENINGER- Tubular Chime Movement
 Mfg. Designation: H-12/116CM
 KLOCKIT NO. 13055

IMPORTANT:

The schematic below is drawn as a general representation of the movement and accessory parts. The drawing is solely for the purpose of providing important dimensions related to the clock case measurements.

Dimensions: Dimension Explanation

- (A)=46-1/2" Dimension from the center of the hand shaft to the tip of the pendulum bob adjust screw.
- (B) Recommended inside case width for pendulum swing. For this dimension, reference the diameter of the pendulum bob and add 6" to 8". This will provide for the start-up pendulum over-swing needed to activate the automatic-beat adjustment feature of the movement.
- (C)=58-1/4" This is the dimension from the center of the hand shaft to the bottom of the center (timekeeping) weight at full weight drop, based on typical movement cable length.
- (D)=10-1/2" This is the dimension from the center of the hand-shaft to the top of the chime tube mount frame. (See note at bottom of sheet.)
- (E)=9-1/2" This is the dimension from the tip of the hand-shaft to the back of the mounted chime tubes.
- (F)=14-1/8" This is the dimension for the overall width of the tubular chime mount frame.
- (G)=2-7/8" This is the dimension from the center of the hand-shaft to the bottom edge of the movement front/back plates that mount to the seat board.
- (H)=1-5/8" This is the maximum dimension from the front movement plate to the front surface of dials not directly mounted to the movement.
- (I)=1-3/8" This dimension is not illustrated on the schematic to the right, but is the space between the front face of the dial and the front of the weight assemblies.

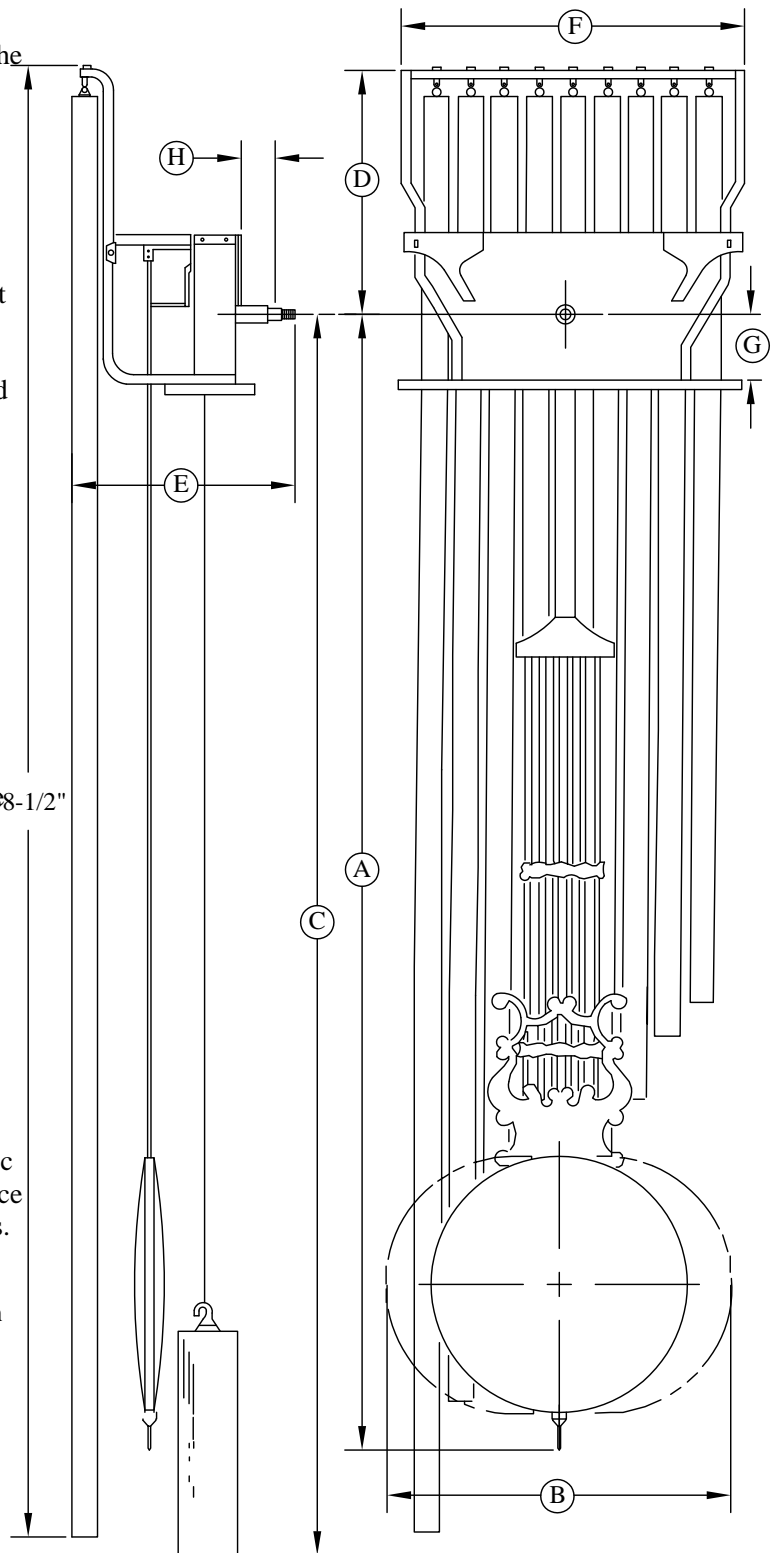

Note : In determining the overall inside clock case length, use the (C-weight drop) dimension plus the greater of either the (D) dimension shown above or the measurement from the center of the hand-shaft hole to the top center edge of the dial. To determine this measurement for traditional arched dials, subtract half the width dimension of the dial from the overall dial height dimension.

KLOCKIT

Stock No. 13055B

See back side for chime lever slot template and key-wind arbor hole pattern (Custom punch dials)

